



1800-2370

### TRUE DUALS WITH FISHTAIL MUFFLERS

- Give your bike a unique performance and sound
- Equal-length headpipes to maximize performance
- Feature 1<sup>3</sup>/<sub>4</sub>" headpipes that flow into 1<sup>7</sup>/<sub>8</sub>" fishtail mufflers
- Chrome heat shields cover headers

PART #	DESCRIPTION
FOR 18-19 FLHC/FLDE	
1800-2370	True Duals w/ 33" fishtail mufflers (no baffle)
1800-2371	True Duals w/ 36" fishtail mufflers (no baffle)



1800-2372

PART #	DESCRIPTION
FOR 18-19 FLHC/FLDE (CONT)	
1800-2372	True Duals w/ 39" fishtail mufflers (no baffle)



1800-2353



### EL DIABLO 2-INTO-1 EXHAUST

- Uses equal-length exhaust headers mated to a cone megaphone muffler
- Collector is one-of-a-kind that is placed in front of the footpeg
- This design is the most efficient mating of exhaust gases to help generate more power
- Rear cylinder header pipe runs forward and wraps around the timing cover for a sleek look
- Improves oil dipstick clearance
- 4" megaphone muffler bodies
- Machined aluminum exhaust tip is powdercoated black and has an etched Cobra logo
- Exhaust tip's reverse cone shape complements the upswept cone muffler
- Full-length heat shields



1800-2354

PART #	DESCRIPTION
FOR 18-19 FLFB/FXBR MODELS	
1800-2385	Chrome
1800-2386	Black
FOR 86-03 XL MODELS W/ MID CONTROLS	
1800-2353	Chrome
1800-2354	Black



## SIDEWINDER 2-INTO-1 EXHAUST SYSTEMS

- Increased power and torque for high-performance baggers
- Stainless steel header construction
- High-flow cat on 07-16 models
- Machined aluminum end cap
- Includes adapters that allow the use of wide band or stock O<sub>2</sub> sensors
- Removable dB reducers included



1800-2387

PART #	DESCRIPTION
--------	-------------

<b>FOR 07-16 FLHT/FLHR/FLHX AND FLTRX MODELS</b>	
--	--

<b>1800-2387</b>	Chrome w/ black highlighted machined end cap
------------------	--

<b>1800-2388</b>	Black w/ black highlighted machined end cap
------------------	---

<b>FOR 95-09 FLT/FLHT/FLHR/FLTR/FLHX MODELS</b>	
---	--

<b>1800-2389</b>	Chrome w/ black highlighted machined end cap
------------------	--

<b>1800-2390</b>	Black w/ black highlighted machined end cap
------------------	---



1800-2390



1801-1360

## GRAND NATIONAL SLIP-ON MUFFLERS

- Race-inspired design with a black-ceramic or chrome finish
- Removable dB reducer for back pressure and sound tuning
- Meet J2825 levels for sound
- All hardware included
- Deep-performance rumble replaces stock whisper tone
- Sold in pairs

PART #	DESCRIPTION
--------	-------------

<b>FOR 18-19 FLFB/FLSL/FXBB/FXBR/FXLR</b>	
---	--

<b>1801-1360</b>	Black ceramic
------------------	---------------

<b>1801-1361</b>	Chrome
------------------	--------

<b>FOR 18-19 FLHC, FLDE</b>	
-----------------------------	--

<b>1801-1362</b>	Chrome
------------------	--------



1801-1362

**HOGTUNES**  
*Audio Solutions For The Great American Cruiser*

**200 WATT AMP/FOUR SPEAKER KIT**

- Complete front and rear speaker kit with 200-watt 4-channel amp
- Amp is set up for any software changes H-D may apply to radios in future
- Includes Hogtunes REV 450-RM amp and GEN3 – 6,5” front and rear speakers with grilles
- 100% plug-n-play and includes all required hardware to complete installation
- No radio reflash is required

**NOTE:** Not for use on CVO models with factory amplifiers installed.



PART #	DESCRIPTION
4405-0536	For 14-19 FLHTCU/FLHTK/FLHTCUG models

**HOGTUNES**  
*Audio Solutions For The Great American Cruiser*

**200 WATT AMP/5 1/4” FRONT AND REAR SPEAKER KIT**

- Includes GEN3 front and rear speakers and 200-watt, 4-channel amplifier
- 100% plug-n-play wire harness
- Includes custom mounting “arms” to secure amp above radio
- Comes with everything required to complete installation

**NOTE:** Not compatible with CVO models with factory amplifiers installed.



PART #	DESCRIPTION
4405-0535	For 00-13 FLHTK/FLHTCU/I models



**6,5” LOWER SPEAKER ADAPTERS FOR TWIN-COOLED™ MODELS**

- High-quality, injection-molded adapters for most 6,5” speakers with maximum mounting depth of 2,25”
- Body is matte black, with a gloss black face
- Does not require relocation of factory coolant tank in brake side lower fairing
- Wire harness and speaker mounting screws included
- Speaker grilles are not included
- Sold in pairs



PART #	DESCRIPTION
4405-0532	For 14-19 FLHTK/FLHTCUTG, 16-19 FLTRU

**SENA**

**10C PRO CAMERA**

- Shoots in QHD: 1440p/30fps; 1080p/60fps; 1080p/30fps with a resolution of 3,7 MP
- 135° field of view
- Features Smart Audio Mix™, which mixes audio from the intercom and music from your smartphone straight into your video
- Allows riders to take and make phone calls and listen to music and GPS
- Built-in FM tuner
- Four-way universal intercom capability to stay in touch with up to three other riders
- Bluetooth® intercom allows connectivity with other riders up to one mile away
- Connectivity to on-bike entertainment systems
- Integrated voice prompts advise riders on use of the device with instant status updates
- Riders have the ability to link 10C Pro with Sena camera apps and headset apps (for Android® and iPhone®)
- Previews images using Sena smartphone apps directly on a smartphone through built-in WiFi



PART #	DESCRIPTION
4402-0781	10C Pro Motorcycle Bluetooth® Camera and Communication System



## WILD ASS™

Add comfort to every ride with a high-quality seat air cushion from Wild Ass™. A series of adjustable interconnected air cells in the cushion conform to the rider's shape to provide maximum comfort, reduced shock vibration and improved air circulation for a cooler, more comfortable seat every time you ride.



0821-2901

0821-2905



WILDASS®  
MOTORCYCLE AIR CUSHION



0821-2909

## AIR SEAT CUSHIONS

- Eliminate painful pressure points and promote blood circulation by utilizing adjustable interconnected air cells which conform to the rider's shape regardless of weight or seating position
- Reduce shock and vibration to reduce lower back pain; improve air circulation under the rider to disperse heat and perspiration
- Add shock absorption to provide greater overall seat comfort
- Three size options: Smart, Sport and Pillion
- Smart (39,5 cm W x 86 cm L x 51 mm H (15,5" x 34" x 2")) is a universal fit for most Harley-Davidson Dresser/Touring models; special features include a wide front-to-back cutout to reduce contact with the scrotum, prostate and tailbone; tapered front and back air cells provide optimal fit for elevated front and back seat contours and also improve leg passage
- Sport (32 cm W x 32 cm L x 51 mm H (12,5" x 12,5" x 2")) was designed with a 15 cm (6") front to match the narrow seat profile of most non-Touring Harley models; special features include a narrow front with tapered cells to reduce contact with the scrotum and provide easy leg passage; back cutout area reduces contact with tailbone

- Pillion (23 cm W x 29 cm L x 51 mm H (9" x 11,5" x 2")) is a universal fit for passengers on almost all motorcycles; may also be used by the rider on very short or narrow saddles; special features allow the passenger or rider to use the Pillion lengthways or sideways
- Three cushioning options: Classic, Air Gel and Lite
- Classic cushions are made with medical-grade neoprene rubber for the ultimate in comfort, elasticity and natural "butt feel" in a motorcycle seat cushion
- Air Gel features three layers of polyurethane with gel pads inserted inside each individual air cell to provide additional cushioning, shock absorption and vibration dampening; can also be used without air when the rider wishes to feel 100% "close to the bike" yet needs some additional cushioning
- Lite is made of economical, lightweight polyurethane and reduces painful pressure points, promotes blood circulation, reduces heat and moisture buildup and lowers shock and vibration better than any other low-cost comfort product

PART #	DESCRIPTION
<b>SMART</b>	
0821-2901	Classic
0821-2902	Air Gel
0821-2903	Lite
<b>SPORT</b>	
0821-2904	Classic
0821-2905	Air Gel

PART #	DESCRIPTION
<b>SPORT (CONT)</b>	
0821-2906	Lite
<b>PILLION</b>	
0821-2907	Classic
0821-2908	Air Gel
0821-2909	Lite



0803-0611



0803-0610

## SUPER TRIPPER™ SEATS

- High-quality expanded vinyl covering
- Classic style features traditional black stitch lines
- Carbon style features carbon-fiber-like vinyl center panel and detailed gunmetal stitching
- Front seat 29 cm (11,5") W, rear seat 20,5 cm (8") W

PART #	DESCRIPTION
<b>FOR 14-17 FXDF</b>	
0803-0611	Classic style
0803-0610	Carbon style

0803-0605



0803-0606

## STEP-UP LS SEATS

- Saddlemen has collaborated with top freestyle performers to create the new T-sport inspired step-up lattice stitch (LS) seats
- Infuse old-school lattice stitch retro styling with a modern twist
- High lumbar keeps the rider locked into the seat
- Feature Saddlemen's Ultra-Foam which is formulated to provide a perfect balance of rigidity and user compliance with integrated GelCore™ technology
- Black or brown whisper-grain SaddleHyde™ covers
- Install easily with all necessary mounting hardware and instructions included

PART #	DESCRIPTION
FOR 99-03 FXD	
0803-0605	Black
0803-0606	Brown



## FUELPACK PRO WIDEBAND TUNING KIT FOR FUELPACK FP3

- For quick, precise auto tuning using the Fuelpak FP3
- Allows FP3 to collect four times more data for quicker and more accurate full mapping sessions
- Plug-and-play installation adds wideband tuning
- Includes two 18 mm wideband Bosch O<sub>2</sub> sensors and control module
- Can be used on multiple bikes with a Fuelpak FP3 installed
- Full mapping sessions complete in as little as fifteen minutes
- Exclusive dealer cloud server account for uploading each dyno session and building private library of FP3 maps

PART #	DESCRIPTION
3807-0474	For 07-19 H-D models



## CLARITY AIR CLEANERS

- CNC machined from billet aluminum
- Allows for viewing of the internal moving intake components
- Backing plate promotes smooth airflow into the carb/throttle body
- Includes high-volume K&N air filter
- All mounting hardware included
- Available in chrome and Black Ops™ finishes



PART #	DESCRIPTION
FOR 17-19 FLHT/FLHX/FLHR/FLTRX/FLTRU AND HD FL TRIKE MODELS	
1010-2349	Chrome
1010-2350	Black Ops



## CLARITY TRANSMISSION TOP COVER

- Designed to match the rest of the Clarity line; gives a unique opportunity to see the inner workings of the transmission
- Designed as a direct replacement for your stock top cover
- CNC-machined from billet aluminum and polycarbonate
- Proprietary abrasion- and UV-resistant film to protect yellowing, marring and breakage
- Machined RSD logo
- Available in Contrast Cut™ finish
- All mounting hardware included
- Gasket included



PART #	DESCRIPTION
1105-0233	For 17-19 FLHT/FLHR/FLHX/FLTRX/FLTRU



## DETACHABLE LUGGAGE RACKS

- Same proprietary release mechanism as the backrests
- Installed or removed in a matter of seconds
- Can be used with stock/OEM docking kits

PART #	DESCRIPTION
FOR 18-19 FLFB/FLFBS/FXBR/FXBRS	
1510-0439	Chrome
1510-0440	Black powder-coat

1510-0439



1510-0440



## JAGG OIL COOLERS

Engineered using HyperFlow Technology, Jagg oil coolers are built using an organized dynamic of systems all working together to efficiently cool the motorcycle's oil without impeding flow. The end result is a stylish, durable and functional oil cooler that works hard to keep things cool to extend engine oil life.



0713-0205



0713-0210



0713-0207



0713-0214



## UNIVERSAL OIL COOLERS

- Fully-brazed construction, powdercoated gloss black
- Perfect for the fabricator, customizer and racer
- Same oil coolers that are used in all high-quality Jagg oil cooler systems
- Sold individually without mounting hardware
- Dimensions: A = Length, B = Width, C = Depth

PART #	DESCRIPTION	DIMENSIONS (INCHES)
0713-0205	6-row w/ 2 mounting tabs	A: 8,25", B: 2,50", C: 1,50"
0713-0206	14-row w/ 4 mounting tabs	A: 8,25", B: 5,25", C: 1,50"
0713-0207	6-row w/ 2 mounting bosses	A: 8,25", B: 2,50", C: 1,50"
0713-0208	6-row w/ 2 mounting bosses	A: 8,25", B: 2,50", C: 1,50"
0713-0209	6-row w/ 2 mounting bosses	A: 8,25", B: 2,50", C: 1,50"
0713-0210	10-row w/ 2 mounting bosses	A: 8,25", B: 4,00", C: 1,50"
0713-0211	10-row w/ 2 mounting bosses	A: 8,25", B: 4,00", C: 1,50"
0713-0212	10-row w/ 2 mounting bosses	A: 8,25", B: 4,00", C: 1,50"
0713-0213	10-row w/ 2 mounting tabs	A: 8,25", B: 4,00", C: 1,50"
0713-0214	10-row w/ 2 mounting tabs and 2 mounting bosses	A: 8,25", B: 4,00", C: 1,50"



## HYPERFLOW LIFETIME OIL FILTER

- Precision CNC-machined billet aluminum body
- Knurled non-slip grip surface
- 30 micron absolute filtration
- Cleanable/reusable surgical-grade stainless steel woven filter element
- Disassembles without tools for easy inspection and cleaning
- Extreme flow volume greatly exceeds OEM filters
- Built-in rare-earth magnet



PART #	DESCRIPTION
0712-0555	For all H-D models w/ front-mount spin-on oil filters (3/4"-16 thread)



## MINIATURE THERMAL SWITCHES

- Switch on any 12V powered accessory at the prescribed temperature
- Thermal switch is naturally open (off) to switch on 12V powered accessory at prescribed temperature
- Available presets: 180/190/200 °F
- NPT 1/8" threaded probe end plumbs into hot oil source to access heat for activation
- Simple brass prongs offer easy wire connections
- Sold each



0713-0220

PART #	DESCRIPTION
0713-0220	180 °F preset switch
0713-0221	190 °F preset switch
0713-0222	200 °F preset switch





0612-0423



## CLUTCH MASTER CYLINDER COVER KITS

- Chrome finish
- Includes gasket and mounting screws
- Replacement gaskets sold as 5-pack



0612-0424



0940-1743



## SPLIT SKULL POINTS COVERS

- Die-cast construction
- Available with a chrome or black finish
- Match other Drag Specialties Split Skull products

0940-1744



PART #	DESCRIPTION
<b>COVER KITS</b>	
<b>0612-0423</b>	For 17-18 FLHTCUTG/FLRT models; repl. OEM #36700129
<b>0612-0424</b>	For 17-19 FLHT/FLHR/FLHX/FLTRX/FLTRU and 19 FLHTCUTG/FLRT models; repl. OEM #36700130
<b>REPLACEMENT GASKETS</b>	
<b>0612-0425</b>	For PART #0612-0423; repl. OEM #36700147
<b>0612-0426</b>	For PART #0612-0424; repl. OEM #36700131

PART #	DESCRIPTION
<b>FOR 17-19 M-EIGHT</b>	
<b>0940-1743</b>	Chrome w/ black skull
<b>0940-1744</b>	Black w/ chrome skull

## SCALLOPED HANDLEBAR CLAMP

- Gloss black finish
- Fit 25,4 mm (1") OD diameter bars

**NOTE:** Use kit PART #0603-0555 to install clamp mounted gauges.



PART #	DESCRIPTION
<b>0603-0812</b>	For most 74-17 models with 89 mm (3 1/2") on-center risers and offset mounting holes

## GLOSS BLACK HANDLEBAR CLAMPS WITH SKIRT

- Die-cast clamp has a skirt design to cover the underside of the clamp when using our pullback-style risers
- Designed to work on 25,4 mm (1") OD diameter bars

**NOTE:** Use kit PART #0603-0555 to install clamp-mounted gauges.



0603-0810



0603-0811

PART #	DESCRIPTION
<b>FOR MOST 74-17 MODELS WITH 89 MM (3 1/2") ON-CENTER RISERS AND OFFSET MOUNTING HOLES</b>	
<b>0603-0810</b>	Finned
<b>0603-0811</b>	Smooth

## SPLIT SKULL FUEL DOORS

- Die-cast construction
- Mount using existing hardware
- Match other Drag Specialties Split Skull products

0703-0791



0703-0792



PART #	DESCRIPTION
<b>FOR 08-19 FLHT/FLHX/FLTRX AND H-D FL TRIKE MODELS (EXCEPT FLRT)</b>	
<b>0703-0791</b>	Chrome w/ black skull
<b>0703-0792</b>	Black w/ chrome skull

## SPLIT SKULL DUMMY GAS CAP

- Die-cast aluminum construction
- Replaces the left-side OEM fuel gauge
- Available in black
- Sold each



PART #	DESCRIPTION
<b>0703-0790</b>	For L96-19 Big Twin, L96-19 XL w/ screw-in gas cap (except 18-19 Softails)

## CRANK POSITION SENSOR

- High-quality replacement sensor

PART #	DESCRIPTION
<b>1022-0197</b>	For 99 FLHT/FLHR/FLTR, 99 FXD/FXDWG; repl. OEM #32497-99/99A



## REKLUSE



Innovators in clutch technology, Rekluse develops clutches with the philosophy that good just isn't good enough. The manual clutch TorqDrive clutch systems provide more clutch discs in less space for increased friction and torque capacity. This unlocks the full power potential of V-Twin engines without the need of super-stiff springs or a clutch lockup device. Rekluse develops, engineers and manufactures all their clutch products in-house in Boise, Idaho.



### V-TWIN RADIUSX CLUTCH KITS

- RadiusX is a high-performance centrifugal auto clutch combining Rekluse's TorqDrive® and EXP technologies
- TorqDrive provides more clutch disks in less space, allowing for maximum performance within the bike's existing clutch footprint
- Full clutch control and use of the lever is retained for a no-compromise riding experience
- RadiusX offers dead-on clutch engagement every time and allows riders to take off and stop in gear without using the clutch lever
- Riders will experience maximum power delivery
- Rekluse TorqDrive friction disks deliver higher torque capacity and increased power transfer
- With RadiusX, you'll confidently navigate traffic and slow speed conditions
- Rekluse sleeves eliminate basket wear and notching
- Installing RadiusX does not require modification to stock components
- Shifting the transmission remains unchanged (clutch lever use is recommended for shifting)



1130-0312



1130-0315

PART #	DESCRIPTION
<a href="#">1130-0314</a>	For 18-19 Softail models w/ cable actuated clutch
<a href="#">1130-0308</a>	For 98-17 Big Twin Models w/ cable actuated clutch (except models with slipper/assist clutch)
<a href="#">1130-0312</a>	For 15-19 Big Twin models w/ hydraulic actuated clutch
<a href="#">1130-0309</a>	For 98-17 Big Twin Models w/ hydraulic actuated clutch
<a href="#">1130-0311</a>	For 00-06 Screamin' Eagle Big Twin models w/ hydraulic actuated clutch
<a href="#">1130-0316</a>	For 15-19 XG 500/750/750A models w/ cable actuated clutch
<a href="#">1130-0315</a>	For 15-19 Indian Scout/Scout Sixty/Scout Bobber



### V-TWIN TORQDRIVE® CLUTCH KITS

- TorqDrive provides more disks in less space, allowing us to add up to six additional friction disks to the clutch pack over stock
- More frictions = more torque capacity, thus unlocking the full power of your engine without the need to add stiffer pressure plate springs or a lock-up device
- TorqDrive provides smoother shifting and improved lever feel
- Rekluse basket sleeves eliminate basket wear and notching



1130-0304

PART #	DESCRIPTION
<a href="#">1130-0307</a>	For 13-19 Big Twin models w/ slipper/assist clutch
<a href="#">1130-0306</a>	For 98-17 Big Twin models (except models w/ slipper/assist clutch)
<a href="#">1130-0304</a>	For 15-19 XG500/750/750A
<a href="#">1130-0305</a>	For 15-19 Indian Scout/Scout Sixty/Scout Bobber



### V-TWIN CORE EXP CLUTCH KIT

- Core EXP 3.0 is a centrifugal auto clutch featuring Rekluse's EXP (auto clutch) technology
- Full clutch control and use of the lever is retained for a no-compromise riding experience
- Core EXP 3.0 offers dead-on clutch engagement every time and allows riders to take off and stop in gear without using the clutch lever
- With Core EXP 3.0, you'll confidently navigate traffic and slow-speed conditions
- Rekluse's billet center hub and pressure plate convert the clutch to six coil springs which improves lever feel, clutch performance, and durability
- Increased oil passages in the center hub and pressure plate move more oil through the clutch, decreasing operating temperatures and increasing clutch life
- Installing Core EXP 3.0 does not require modification to stock components
- Shifting the transmission remains unchanged (clutch lever use is recommended for shifting)



PART #	DESCRIPTION
<a href="#">1130-0313</a>	For 95-19 XL models





## PRO SHORT FRONT FENDERS

- Performance inspired short front fender
- Stamped from one piece of 14-gauge steel to minimize bodywork
- Direct bolt-on black anodized billet bracket is included
- Fenders allow enough clearance for oversized 14" brake rotors
- 19" fenders measure 5,9" wide and accept all 130/60-19" tires
- 21" fenders measure 5,9" wide and accept all 120/70-21" tires
- 23" fenders measure 6,3" wide and accept all 130/60-23" tires



1401-0679

PART #	DESCRIPTION
<b>FOR 14-19 FLHT/FLHX/FLHR/FLTRX/H-D FL TRIKE MODELS</b>	
1401-0677	19"
1401-0679	21"
1401-0681	23"
<b>FOR 99-13 FLT/FLHT/H-D FL TRIKE MODELS</b>	
1401-0678	21"
1401-0680	23"



0630-2364

0630-2365

## KURYAKYN HEX GRIPS

- Contoured to fit perfectly in your hands for unbeatable comfort
- Ergonomic design features a widened diameter for thumb, index, and middle fingers, and a tapered outer profile for ring and pinky fingers to match the natural shape of your hands
- Premium, durable EPDM rubber compound will not harden, crack or wear over time and provides an ultra soft, cushiony feel for all-day vibration dampening comfort
- Combination of smooth and "hex" shaped embossed rubber provides amazing grip and distinct styling
- Available with chrome or satin black aluminum collars and end caps
- Feature bar-mounted end caps that can be easily replaced with bar end mirrors or weights

**NOTE:** Throttle sleeve not included.

PART #	DESCRIPTION
<b>FOR 25,4 MM (1") HANDLEBARS</b>	
0630-2364	Chrome
0630-2365	Satin black



2103-0412



## U-GROOVE SPARK PLUGS

- Accel's state-of-the-art U-Groove spark plugs with ground electrodes, copper glass inner seal and an electric heat seal to prevent leakage in high-compression engines
- Permit the spark to develop a larger, fuller flash for a more complete burn
- Extra-wide heat range
- Now sold in a 24-pack



2103-0413

PART #	DESCRIPTION
2103-0412	For 99-17 Twin Cam, 86-19 XL models
2103-0413	For 84-99 Evolution Big Twin, 75-81 Shovelhead models

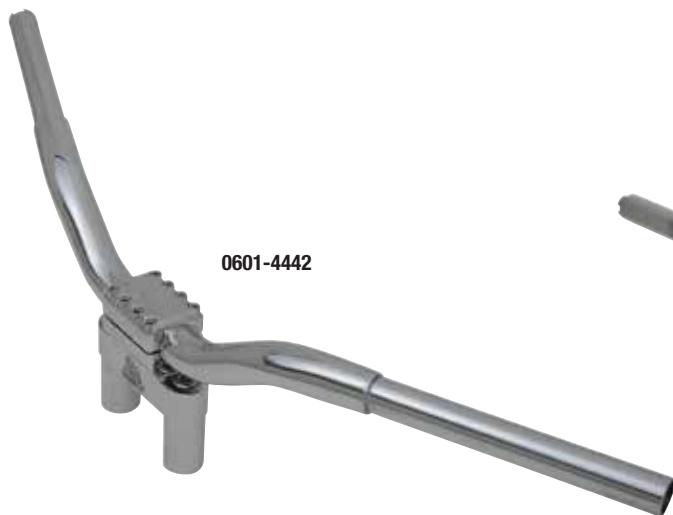

0601-4442



0601-4455



## 32 MM (1 1/4") KAGE FIGHTER STRAIGHT RISER T-BARS

- High-strength steel tubing
- Crossbar has over 35 degrees of rotation to set your perfect angle
- 8 bolt billet aluminum clamp
- Straight heights available in 20,5 cm (8"), 25,5 cm (10"), 30,5 cm (12"), 35,5 cm (14") and 40,5 cm (16")
- 32 mm (1 1/4") pullback heights available in 28 cm (11"), 33 cm (13") and 38 cm (15")
- 89 mm (3 1/2") on-center riser
- Designed for internal wiring

CHROME PART #	GLOSS BLACK PART #	FLAT BLACK PART #	RISE	END RISE	WIDTH	CENTER WIDTH	PULLBACK
0601-4442	0601-4443	0601-4444	10 cm (4")	15 cm (6")	77,5 cm (30,5")	76 mm (3")	11,5" cm (4,5")
0601-4445	0601-4446	0601-4447	15 cm (6")	20,5 cm (8")	77,5 cm (30,5")	76 mm (3")	11,5" cm (4,5")
0601-4448	0601-4449	0601-4450	20,5 cm (8")	25,5 cm (10")	77,5 cm (30,5")	76 mm (3")	11,5" cm (4,5")
0601-4451	0601-4452	0601-4453	25,5 cm (10")	30,5 cm (12")	77,5 cm (30,5")	76 mm (3")	11,5" cm (4,5")
0601-4454	0601-4455	0601-4456	30,5 cm (12")	35,5 cm (14")	77,5 cm (30,5")	76 mm (3")	11,5" cm (4,5")



2401-1076



2401-1075



## MOTOR CASE HARDWARE KITS

- Available in chrome or zinc
- Include all necessary hardware for bolting together the motor case

PART #	DESCRIPTION
<b>FOR 96-98 EVOLUTION BIG TWIN</b>	
2401-1075	Chrome flanged nuts and studs for motor cases
2401-1076	Zinc flanged nuts and studs for motor cases



## CHROME MINI BOARDS

- Economical alternative to factory Harley-Davidson® pegs, boards and highway pegs
- Reversible rubber on one side, chrome with rubber inlays on the other
- Folding stainless steel clevis mounts
- Measure 4" x 4"
- Stainless steel 3/8" mounting bolts fit most arms and clamps
- Sold in pairs

PART #	DESCRIPTION
<b>1621-0856</b>	Chrome mini boards



## CUSTOM ACCENT PEGS

- Chrome pegs with anti-vibration rubber inlays
- Folding stainless steel clevis mounts
- Stainless steel 3/8" mounting bolts will fit most arms and clamps
- Sold in pairs

PART #	DESCRIPTION
<b>1624-0337</b>	Chrome custom accent pegs



## OEM-TYPE CONNECTORS

- Sold each

PART #	DESCRIPTION
<b>2120-0940</b>	For 04-19 HD models Speedo and tri-bar connector, includes 12 female terminals; OEM #72130-04
<b>2120-0941</b>	For 14-19 HD models tour pack light bar connector; includes terminals, wire seals and TPA lock; OEM #6920025
<b>2120-0942</b>	For 17-19 M-Eight models Throttle control connector, includes wire seals, terminals and TPA lock; OEM #6201394



## BULLET BEZELS FOR ProBEAM® TURN SIGNALS

- Aluminum bezel with choice of chrome or gloss black finish and amber lenses
- Will only work with ProBEAM® LED turn signal inserts; see the 2019 Parts Europe FatBook
- Sold as pair

PART #	DESCRIPTION
<b>2020-1731</b>	Gloss black
<b>2020-1732</b>	Chrome



## ALLOY ART

American-made high-quality parts and accessories for your bike. Started in 1999, Alloy Art has been an industry leader in new, innovative products that really add style and performance to your ride. Looking for cool, new and unique products to customize your bike? Look to Alloy Art.



## THE SWINGER

- Three piece CNC-machined aluminum swingarm featuring a bolted, pinned and welded assembly
- Exceptional strength and functionality
- 7 lb. lighter than stock
- Adjustable shock mounts



PART #	DESCRIPTION
1301-0142	For 09-19 FLHT/FLHR/FLHX/FLTRX/FLTRU



## UNIVERSAL DRIVE CUSH CHAIN CONVERSION SYSTEMS

- CNC-machined billet aluminum carrier and hub adapter
- CNC-machined sprocket made of medium to high carbon steel
- Fits any stock Harley-Davidson™ or aftermarket cush drive wheel
- Available with machine finish or black anodized aluminum carrier, and black or gold sprocket



PART #	DESCRIPTION
<b>MACHINED CARRIER</b>	
1201-0860	Black 49T
1201-0861	Gold 49T
1201-0862	Black 51T
1201-0863	Gold 51T
1201-0864	Black 53T
1201-0865	Gold 53T
<b>BLACK ANODIZED CARRIER</b>	
1201-0866	Black 49T
1201-0867	Gold 49T
1201-0868	Black 51T
1201-0869	Gold 51T
1201-0870	Black 53T
1201-0871	Gold 53T



## ROAD 5

### MICHELIN® ROAD 5 TRAIL DUAL-COMPOUND SPORT TOURING RADIALS

- For adventure touring bikes ridden exclusively on the road
- Stop shorter in the wet vs. the leading competitive sport touring tires and the Pilot® Road 3
- Up to 20% longer tread life than Pilot® Road 3 tires (for a single set)
- 2 Compound Technology with all-new silica-charged rubber compounds for excellent grip from -5 °C (23 °F) to 45 °C (113 °F)
- XST+ siping and enhanced tread patterns for optimum grip at all lean angles
- Blackwall
- Tubeless (TL)
- (V)-rated for speeds of 240+ km/h (149+ mph); W-rated for speeds up to 270 km/h (168 mph)



Road 5 Trail Front/Rear

SIZE	LOAD/SPEED INDEX	TL/TT	PART #
<b>FRONT</b>			
110/80 R 19	(59V)	TL	0316-0312
120/70 ZR 19	60W	TL	0301-0759

SIZE	LOAD/SPEED INDEX	TL/TT	PART #
<b>REAR</b>			
150/70 R 17	(69V)	TL	0317-0393
170/60 ZR 17	72W	TL	0302-1257



### ANAKEE ADVENTURE ADVENTURE SPORT TOURING TIRES

- New tread silica compounds for easy maneuverability and precise handling on or offroad, even in wet conditions
- Innovative tread pattern inhibits irregular wear patterns, while evacuating water, dirt and mud
- Excellent stability and rider feedback, thanks to a new high-rigidity casing and tread pattern void ratio
- Bias-ply or radial construction
- Blackwall
- Tubeless (TL)
- H-rated for speeds up to 210 km/h (130 mph); V-rated for speeds up to 240 km/h (149 mph)



Anakee Adventure Front/Rear

SIZE	LOAD/SPEED INDEX	TL/TT	PART #
<b>FRONT BIAS</b>			
90/90 - 21	54V	TL	0316-0362
100/90 - 19	57V	TL	0316-0359
<b>FRONT RADIAL</b>			
110/80 R 19	57V	TL	0316-0360
120/70 R 19	57V	TL	0316-0361

SIZE	LOAD/SPEED INDEX	TL/TT	PART #
<b>REAR RADIAL</b>			
130/80 R 17	65H	TL	0317-0454
140/80 R 17	69H	TL	0317-0455
150/70 R 17	69V	TL	0317-0456
170/60 R 17	72V	TL	0317-0457
150/70 R 18	70V	TL	0317-0458